

**W/G AND COAX SPECIFICATIONS**

	CH 1	CH2	CH3	CH4	CH5	CH6
FREQUENCY (GHz):	2.7 TO 2.9	2.7 TO 2.9	2.7 TO 2.9	1.01 TO 1.11	1.01 TO 1.11	1.01 TO 1.11
VSWR (MAX):	1.2:1	1.3:1	1.3:1	1.3:1	1.3:1	1.3:1
VSWR WOW (MAX):	0.05	0.05	0.06	0.06	0.06	0.06
INSERTION LOSS (dB MAX):	0.15	0.90	1.00	0.80	0.80	0.80
PHASE WOW:	-	1°	1°	1°	1°	1°
PEAK POWER (KW):	35	5	5	15	15	15
MEAN POWER:	3000W	75W	75W	200W	200W	200W

PHASE TRACKING (L-BAND COAX ONLY): ±2° MAX. BETWEEN CHANNELS 4, 5 & 6

ISOLATION: 60dB BETWEEN CHANNELS

WEIGHT: 85 LBS MAX [32.6 Kg] (APPROX WEIGHT 68 LBS)

TEMPERATURE (OPER): -40° TO 55°C  
(STORAGE): -40° TO 70°C

HUMIDITY (RH): 100%

PRESSURE: POSITIVE PRESSURE TO 2 PSI

LEAKAGE: 25cc/min MAX @ 5 PSI ACROSS OPER TEMP RANGE @ 10,000 FT ABOVE SEA LEVEL.

ROTATION RATE: 15 RPM NOMINALLY

LIFE EXPECTANCY: 50,000 HRS. @ 15 RPM MAX (CONTINUOUS)

TORQUE: 15 FT-LBS MAX

PAINT: TBD

MASK AREA INDICATED BY: Δ

**DO NOT PAINT CONNECTORS OR CONNECTOR COVERS**

MARKING: LABELS TO INCLUDE:  
DIAMOND PART NO.  
REVISION  
SERIAL NUMBER

**ROLL-RING SPECIFICATIONS:**

NO. OF CHANNELS: 19 (ALL CHANNELS IDENTICAL)  
VOLTAGE: 120 VAC/24 VDC  
CURRENT: 10 AMPS  
ELECTRICAL ISOLATION: 500 MEGOHMS @ 500 VDC BETWEEN ANY 2 CHANNELS

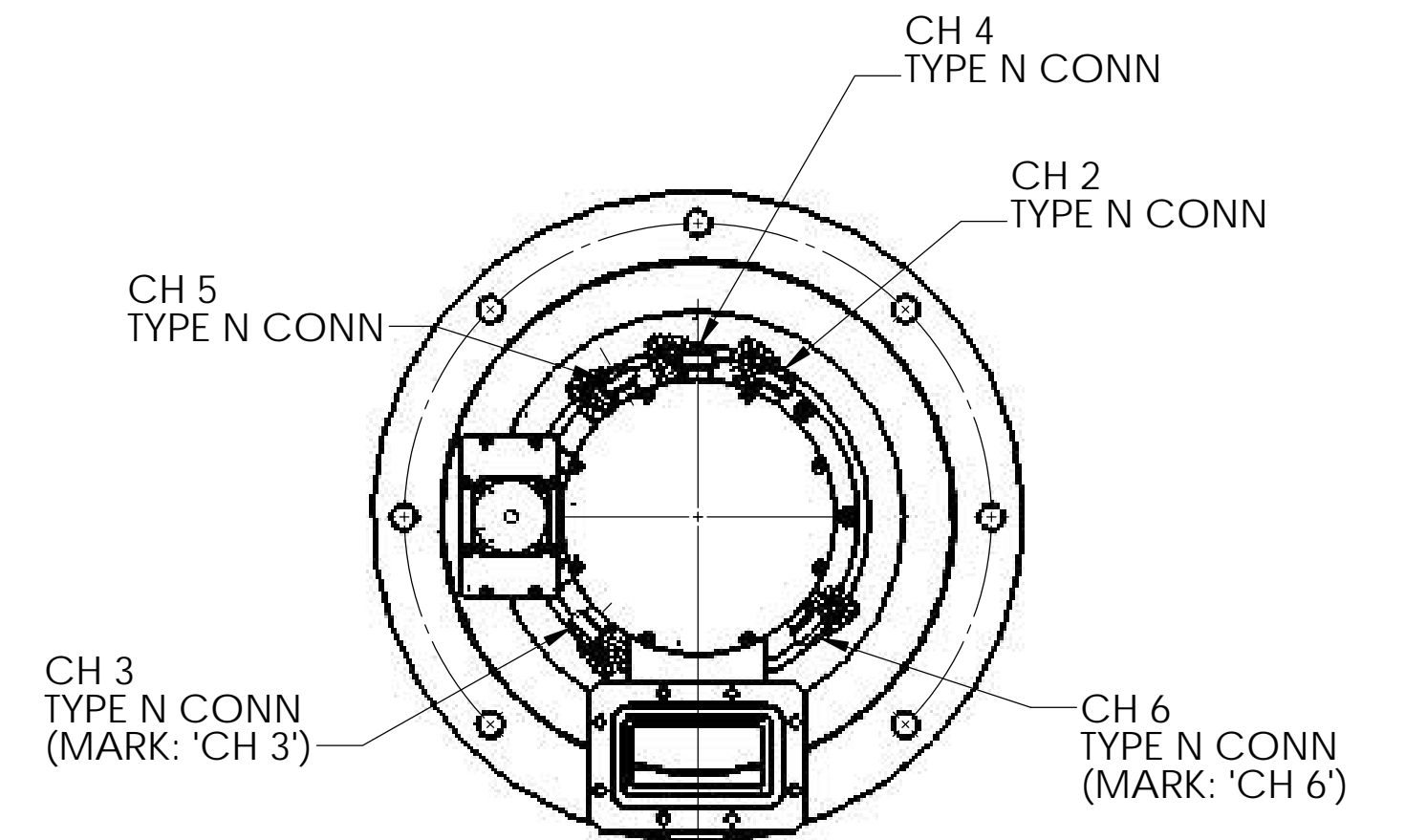
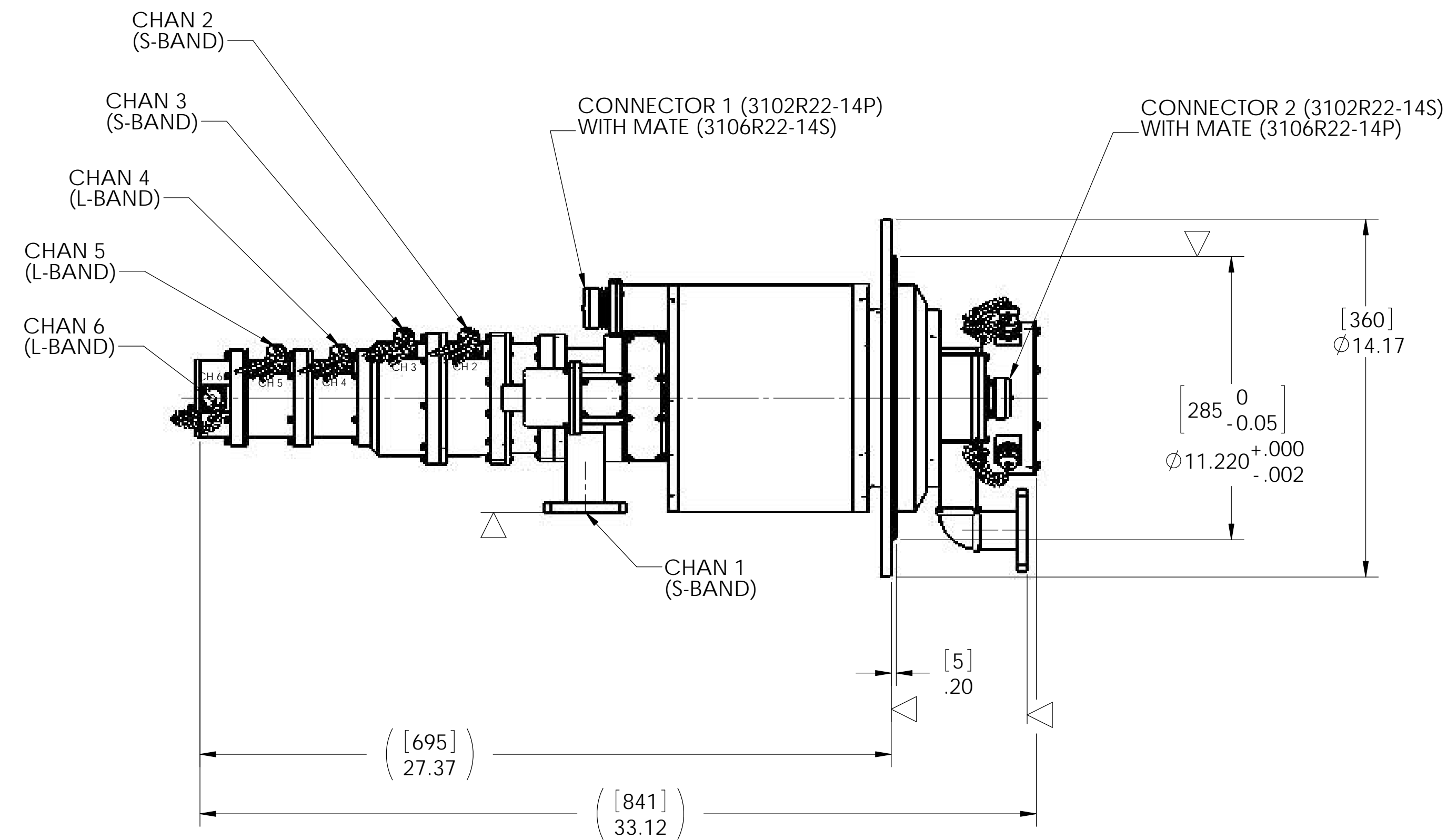
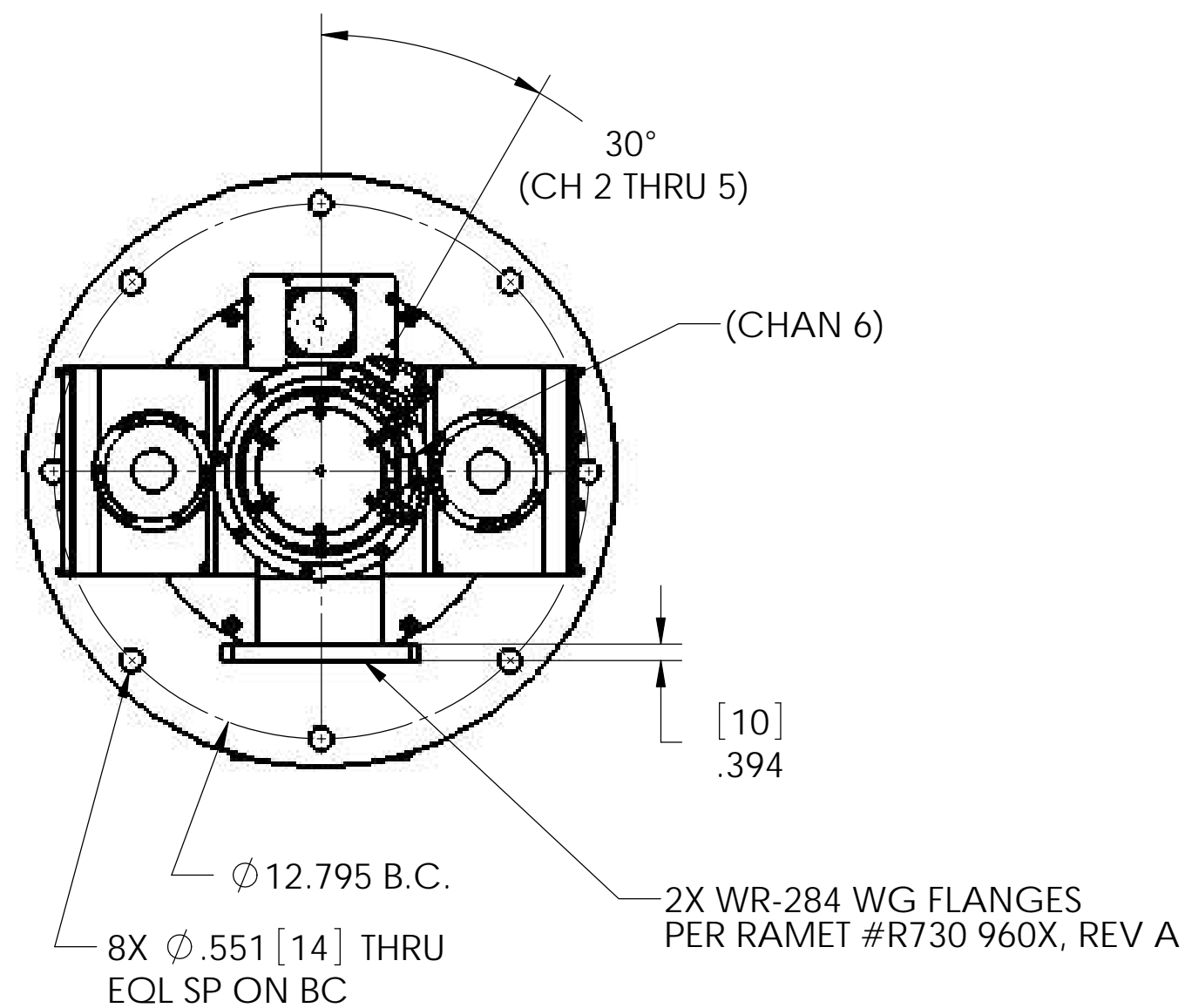
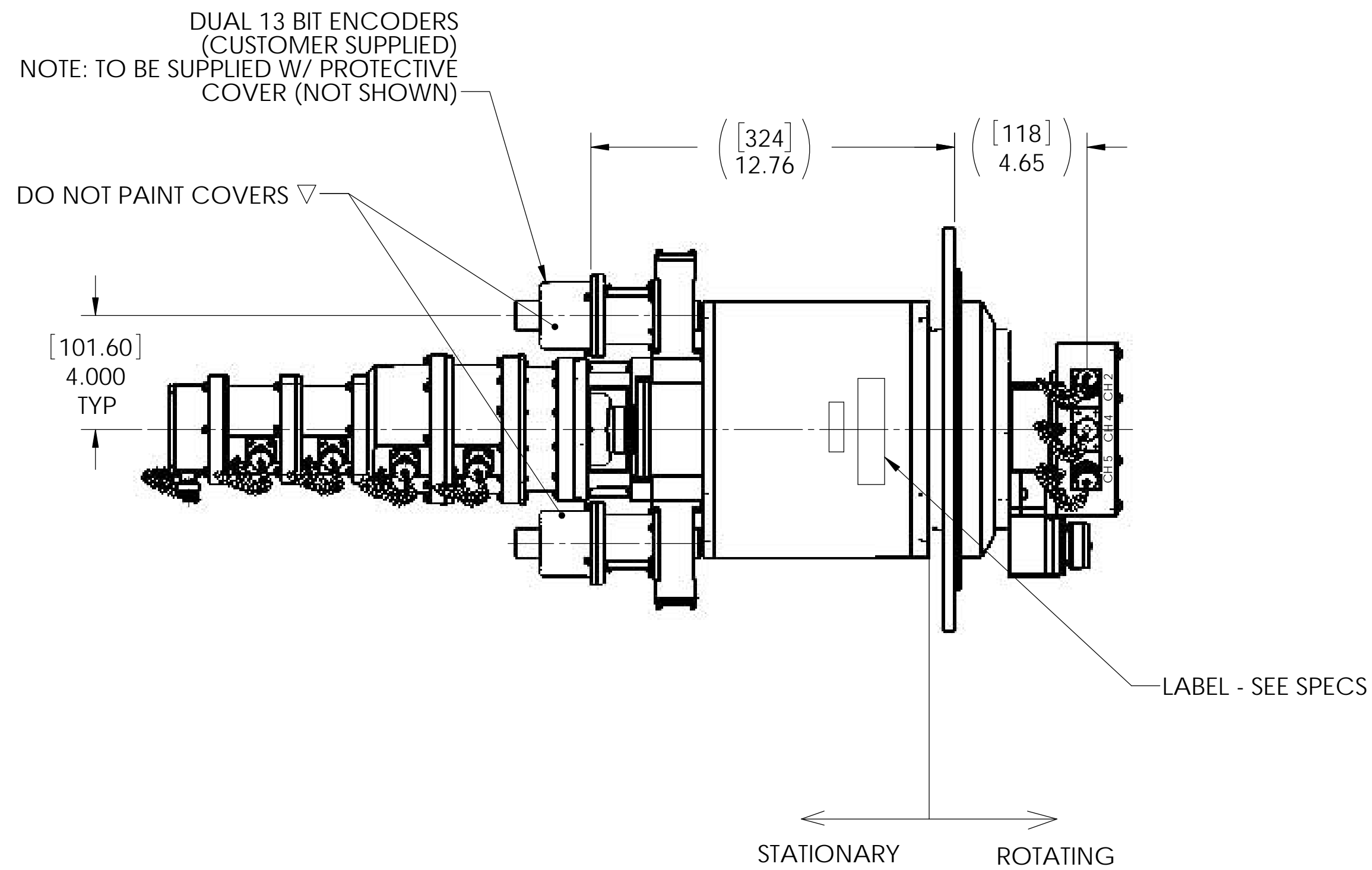

UNIT IS MODE S COMPLIANT.

ROHS COMPLIANT

THIRD ANGLE PROJECTION		DIAMOND ANTENNA & MICROWAVE CORP LITTLETON, MA 01460	
DIMENSIONS ARE IN INCHES. REMOVE ALL BURRS AND SHARP EDGES .005 MAX. UNLESS OTHERWISE SPECIFIED. SURF FINISH 63. TOLERANCES ARE: FRACTIONS DECIMALS ANGLES 2/164 3 PLACES ±.010 ±.012		TITLE: MAIN ASSEMBLY	
SIZE: D	CAGE CODE: 01882	DRAWING NUMBER: CAT 16-2620-0	
SCALE: 1:4	WEIGHT (EST.):	SHEET 1 OF 1	