

SPECIFICATIONS

	CH-1	CH-2
FREQUENCY (GHz): G-1	2.7 - 2.725 - 2.9	2.7 - 2.725 - 2.9
G-2	2.7 - 2.809 - 2.9	2.7 - 2.809 - 2.9
VSWR:	1.20 - 1.15 - 1.20	1.20 - 1.15 - 1.20
VSWR WOW:	0.05	0.05
LOSS (dB):	0.30	0.30
LOSS WOW (dB):	0.10	0.05
POWER PEAK:	1MW	1MW
POWER AVG:	1 KW	1KW
ISOLATION:	50 dB	
SPEED:	10 RPM	
TORQUE:	2.0 FT-LBS	
PRESSURE:	20 PSIG	
LEAK RATE:	20 CC/MIN	
MATERIAL:	ALUMINUM	
FINISH	TBD	

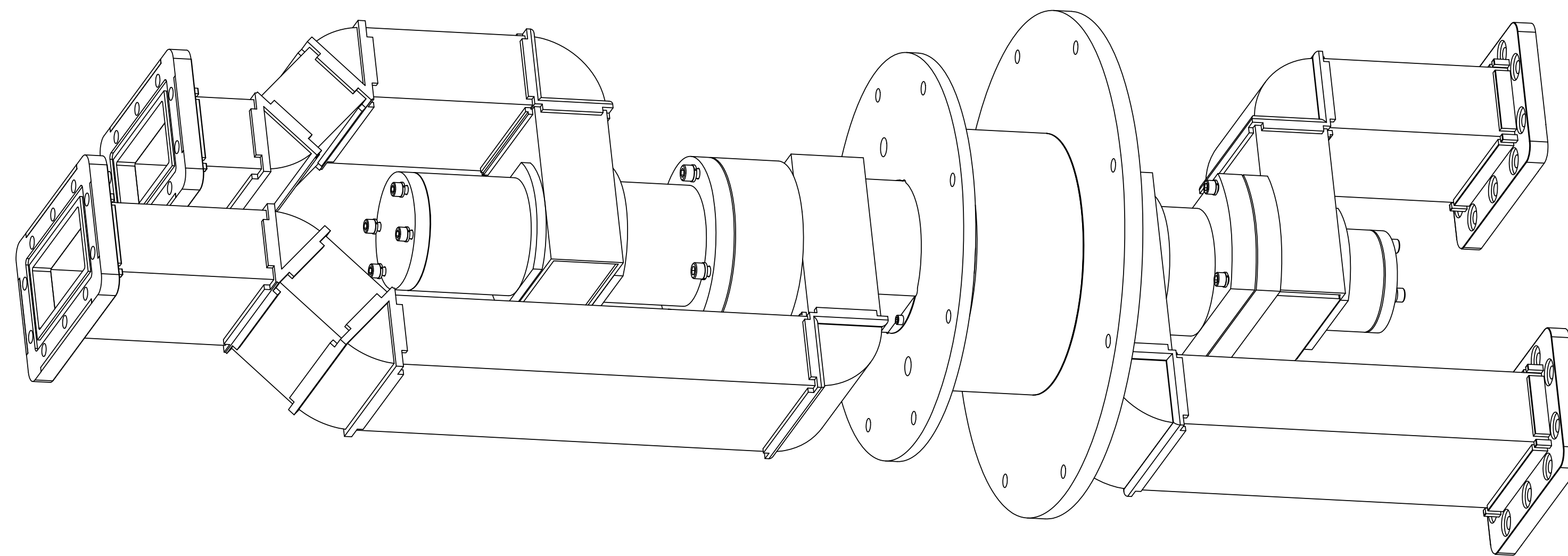

NOTES:
1. MASK SURFACES MARKED ▽

THIRD ANGLE PROJECTION		DIAMOND ANTENNA & MICROWAVE CORP LITTLETON, MA 01460	
DIMENSIONS ARE IN INCHES. REMOVE ALL BURRS AND SHARP EDGES .005 MAX. UNLESS OTHERWISE SPECIFIED. SURF FINISH 63✓ TOLERANCES ARE: FRACTIONS DECIMALS ANGLES ±1/64 ±.005 ±.010		TITLE: DUAL CHANNEL ASSY	
SIZE: D	CAGE CODE: 01882	DRAWING NUMBER: CAT 2281-0	
SCALE: 1:2	WEIGHT (EST.):	SHEET 1 OF 1	