

SPECIFICATIONS

| | <u>CH 1</u> | <u>CH 2</u> | <u>CH 3</u> | <u>CH 4</u> |
|-----------------|------------------|-------------|-------------|-------------|
| FREQUENCY (GHz) | 2.2-2.5 | 2.2-2.5 | 2.2-2.5 | 2.2-2.5 |
| VSWR | 1.5:1 | 1.5:1 | 1.5:1 | 1.7:1 |
| WOW | 0.1 | 0.1 | 0.1 | 0.1 |
| Ins. Loss | 1.0 dB | 1.0 dB | 1.0 dB | 1.0 dB |
| Ins. Loss WOW | 0.2 Db | 0.2 dB | 0.2 dB | 0.2 dB |
| Power Avg | 10 W | 10 W | 10 W | 10 W |
| Isolation | ----- 55dB ----- | | | |
| Connectors | TYPE N | TYPE N | TYPE N | TYPE N |

- Torque 2 FT-LBS
- RPM 10
- Temp Storage -45 to 70°C
- Temp Operating -40 to 70°C
- Weight (est.) 11 lbs
- Material Aluminum
- Finish CHROMATE CVRSN PER MIL DTL-5541, CL 3, TYPE II - ROHS COMPLIANT
- Marking To include as a minimum: Diamond Part # and Serial # (Use Standard Diamond Label)

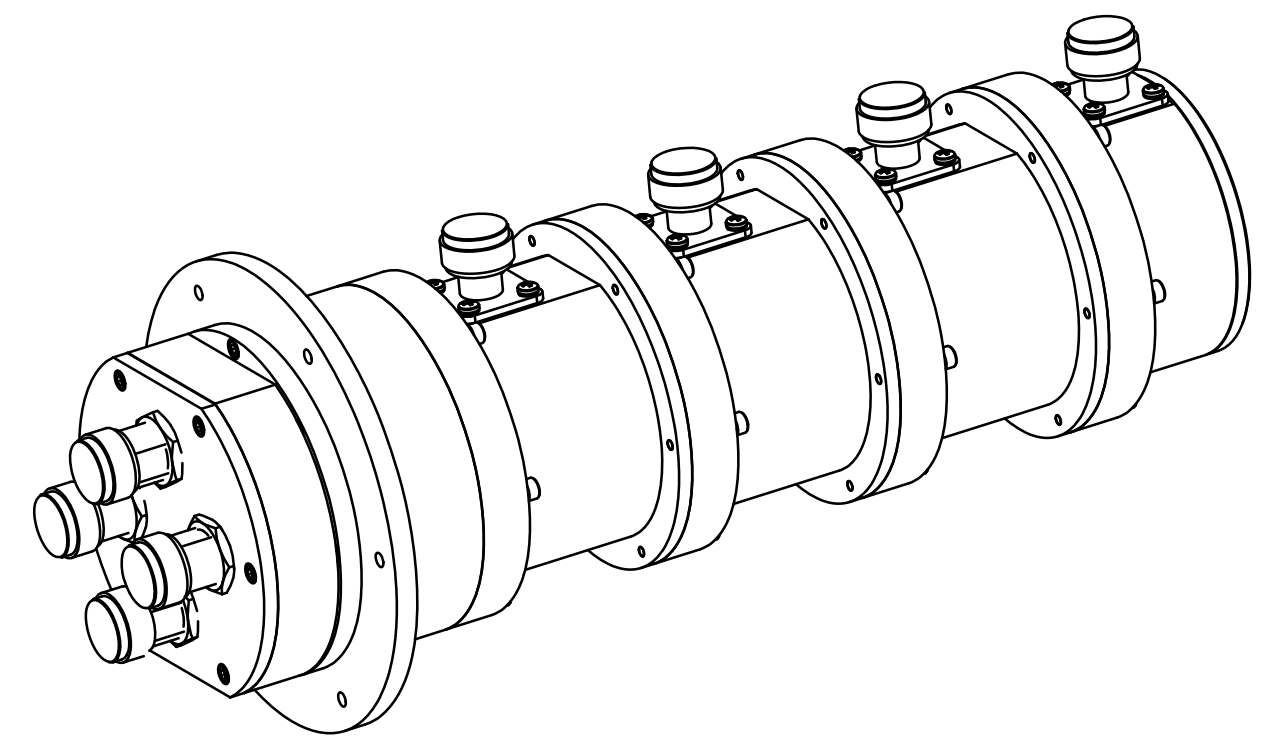

NOTE: PROTECTIVE SCREW ON CAPS PROVIDED FOR ALL CONNECTORS

THIRD ANGLE PROJECTION

DIMENSIONS ARE IN INCHES. REMOVE ALL BURRS AND SHARP EDGES .005 MAX, UNLESS OTHERWISE SPECIFIED. SURF FINISH 63 TOLERANCES ARE:

| | | |
|-----------|----------------|--------|
| FRACTIONS | DECIMALS | ANGLES |
| ±1/64 | 2 PLACES ±.03 | ±1/2° |
| | 3 PLACES ±.010 | |

INTERPRET DIMENSIONS & TOLERANCES PER ASME Y14.5M

DIAMOND ANTENNA & MICROWAVE CORP
LITTLETON, MA 01460

TITLE: **4 CHANNEL COAX ROTARY JOINT**

| | | |
|-------------------|-------------------------|--------------------------------------|
| SIZE: C | CAGE CODE: 01882 | DRAWING NUMBER: CAT 11-2455-0 |
| SCALE: 2:3 | WEIGHT (EST.): | SHEET 1 OF 1 |