

SUMMARY OF SPECIFICATIONS

ELECTRICAL

	CH 1	CH 2
FREQUENCY (GHz)	5.4 - 5.8	5.4 - 5.8
VSWR (MAX)	1.3:1	1.3:1
VSWR WOW	0.1	0.1
INS. LOSS (MAX)	.2dB	.25dB
INS. LOSS WOW	0.05	0.05
POWER, PEAK (MIN)	*800 KW	300 KW
POWER, AVG (MIN)	1 KW	550 W
ISOLATION	-----	50dB -----

* POWER RATING @ 30 PSIG MIN

MECHANICAL

PRESSURE	35 PSIG MAX
LEAK RATE (MAX)	10 CU IN/MIN
TORQUE	20 IN-LBS (MEASURED @ 20°C)
MATERIAL	ALUMINUM ALLOY
WEIGHT (MAX)	10 LBS EST.
FINISH	TBD

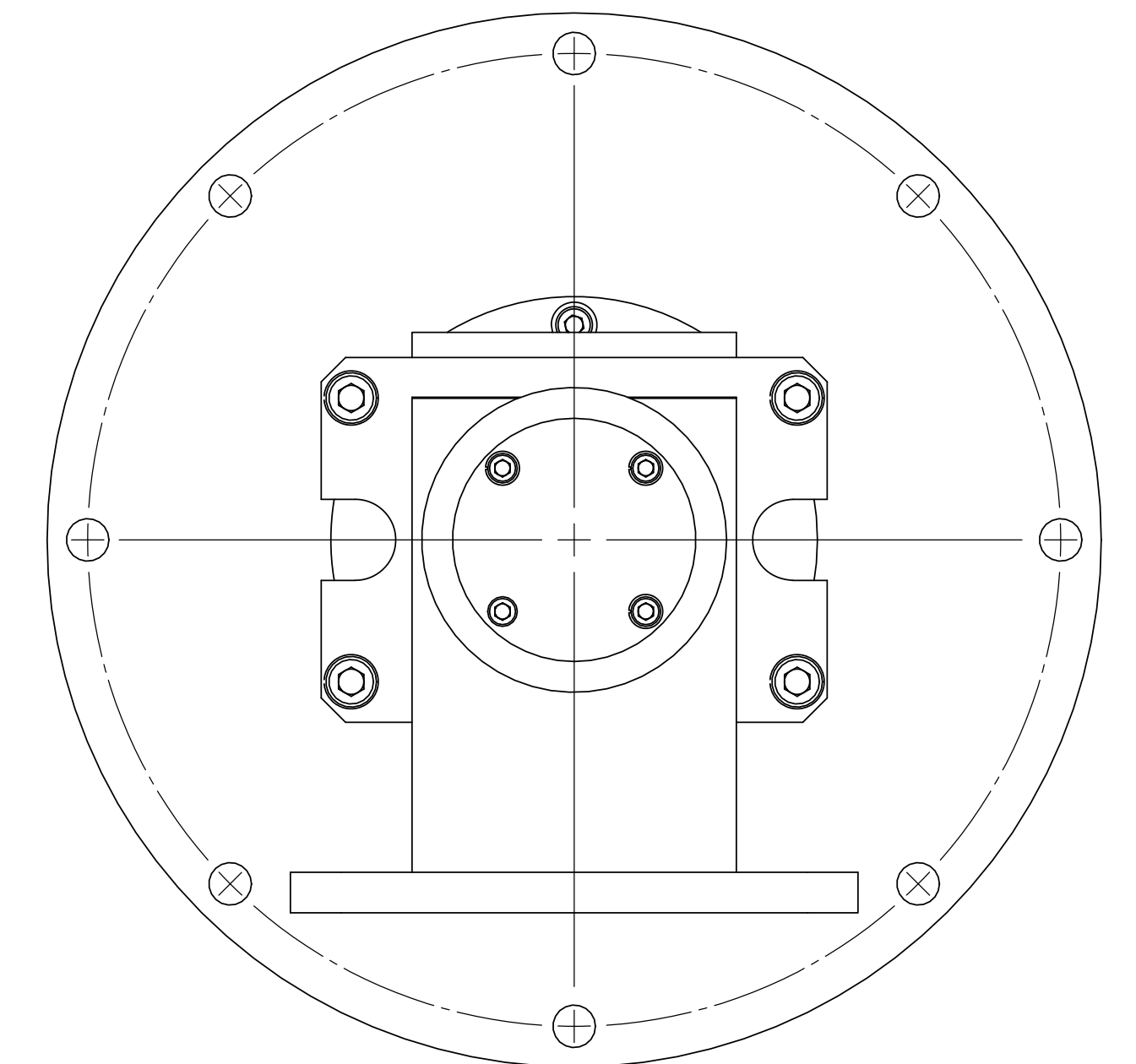
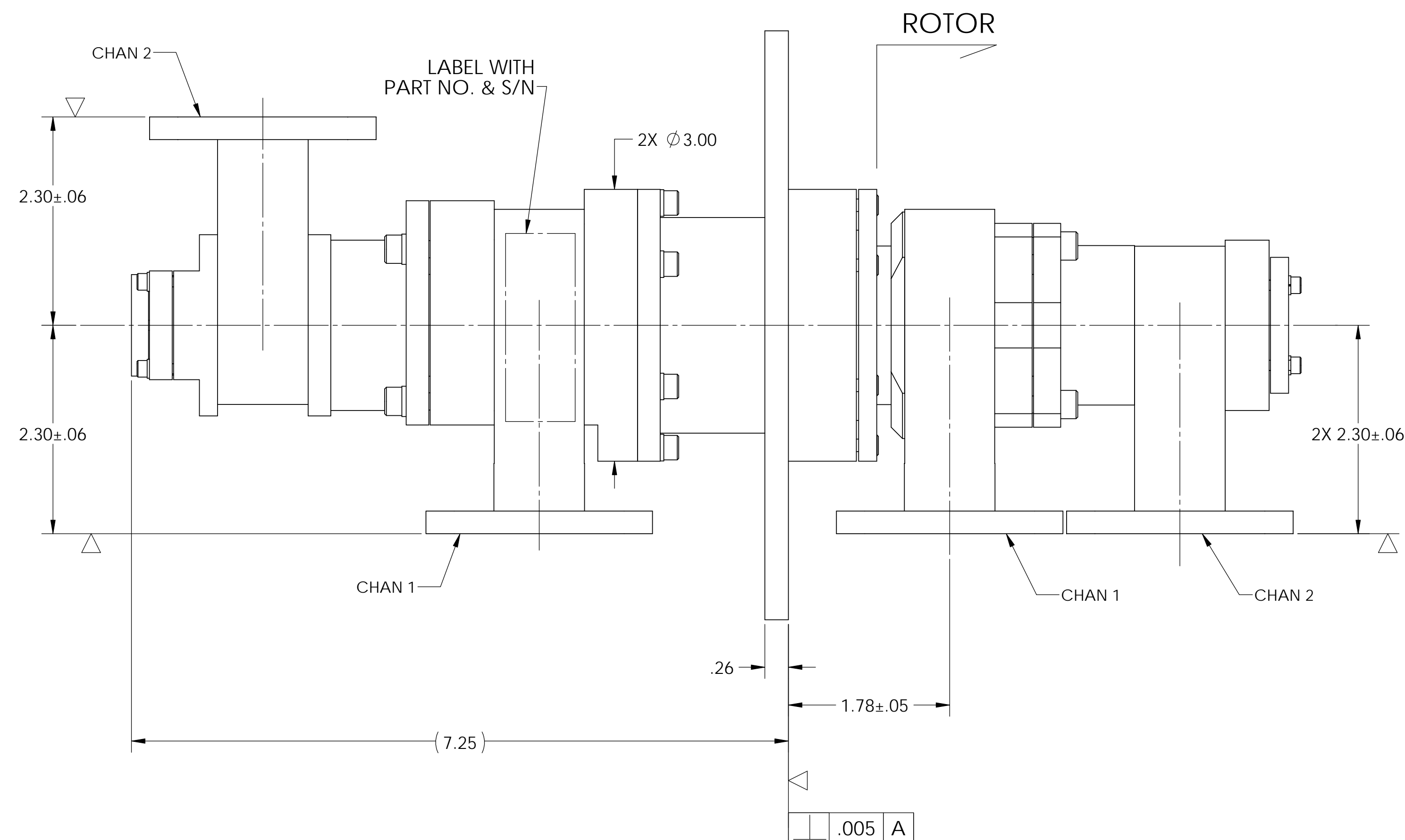
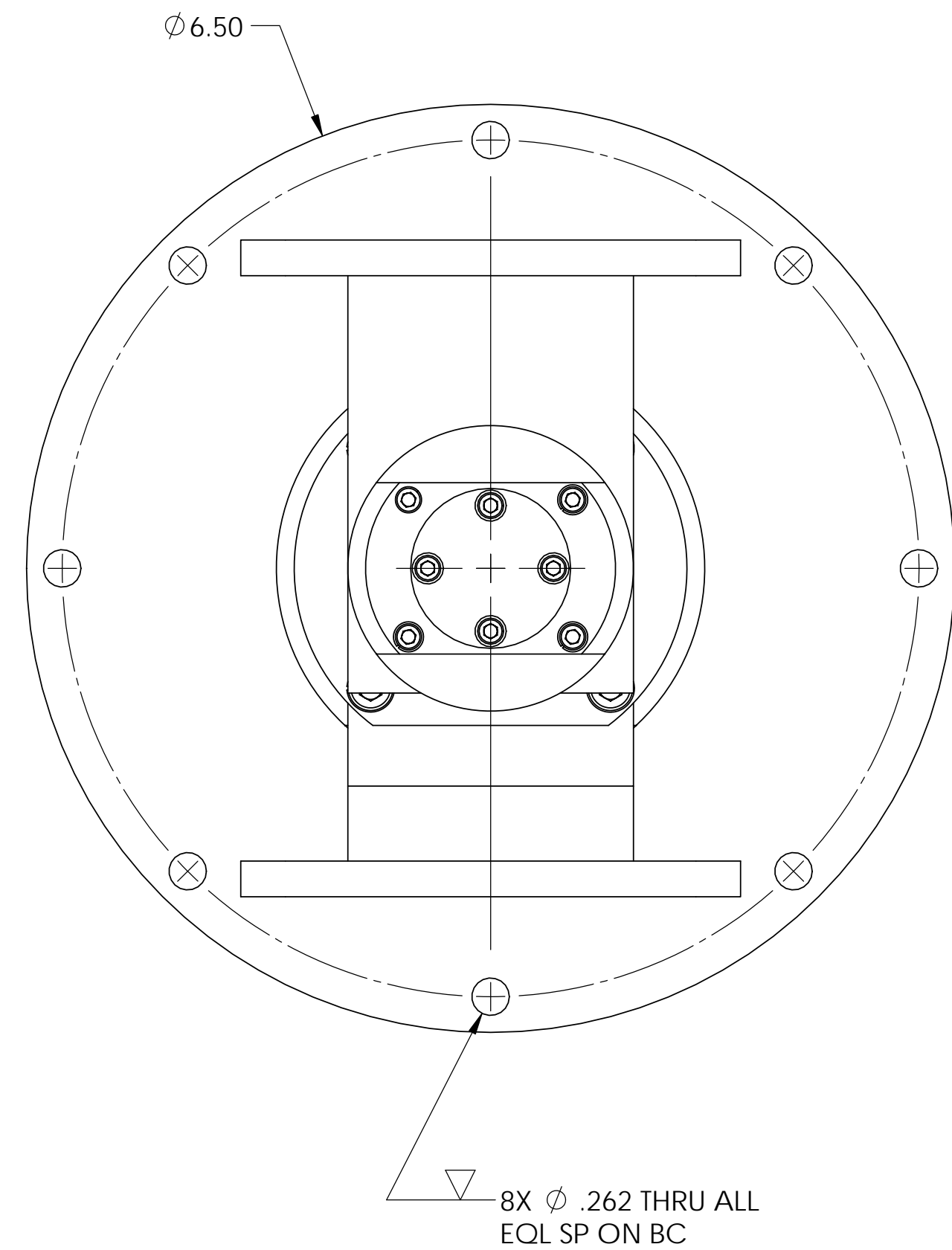
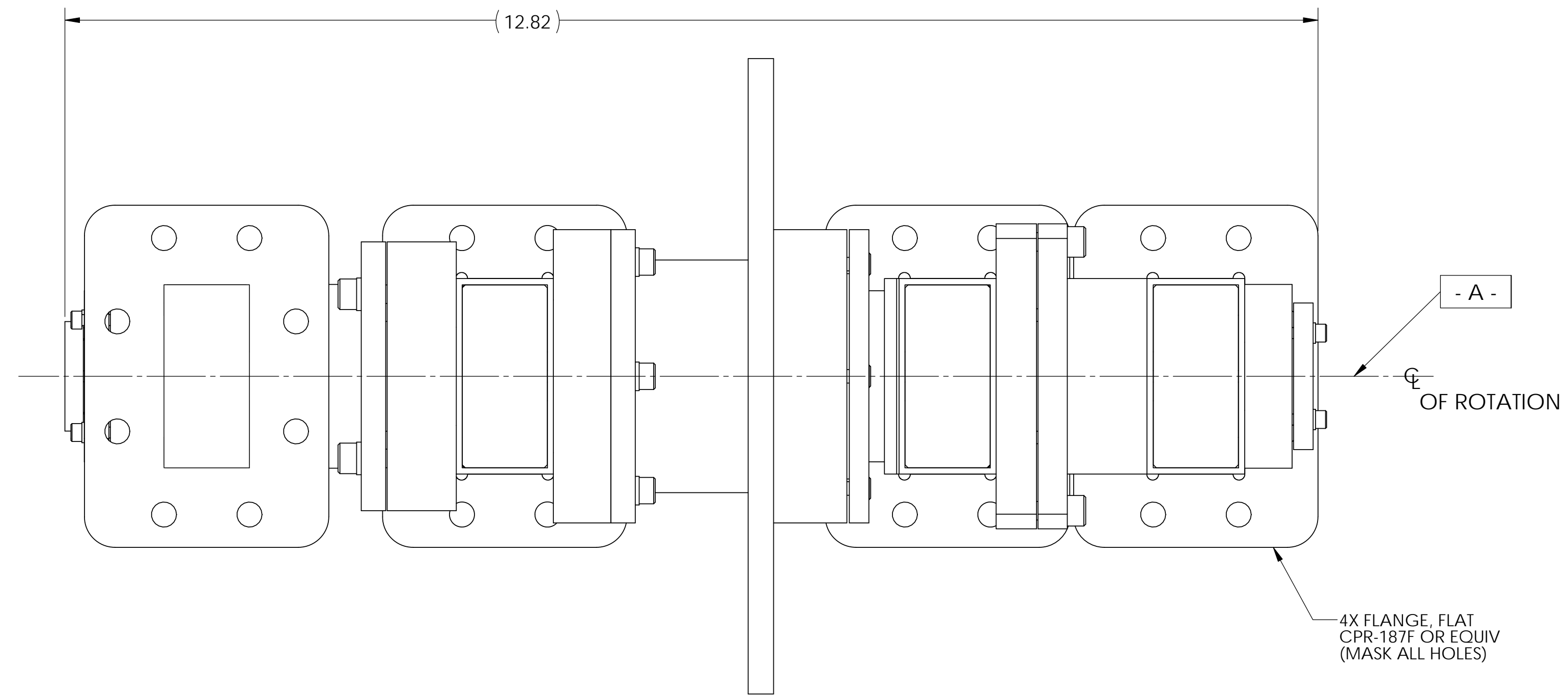

THIRD ANGLE PROJECTION	DIAMOND ANTENNA & MICROWAVE CORP LITTLETON, MA 01460		
DIMENSIONS ARE IN INCHES. REMOVE ALL BURRS AND SHARP EDGES .005 MAX, UNLESS OTHERWISE SPECIFIED. SURF FINISH 63/ TOLERANCES ARE: FRACTIONS DECIMALS ANGLES 1/164 3 PLACES ±.010	TITLE: WR187 2 CHAN C-BAND		
SIZE: D	CAGE CODE: 01882	DRAWING NUMBER: CAT 16-22115-0	
SCALE: 1:1	WEIGHT (EST.):	SHEET 1 OF 1	